



Owner's Reference

PS AUDIO®

®



aspen

FR30 LOUDSPEAKER



PS AUDIO®

Table of Contents

aspen® FR30

Safety Information	2
Introduction	3
Thank You	3
Contact Information	3
A Message From The Design Engineer	3
Getting Started	4-8
Included with the aspen FR30	4
Unpacking Instructions	4-5
Configuring Speaker Feet	6-7
Speaker Accessories	7
Jumper / Input Wiring (bi-amp, bi-wiring)	8
Operation Guide	9-10
Basic speaker setup and placement	9
Rear panel controls	10
Specifications	11
Warranty	12-13
Registering Your Product	12
What This Warranty Covers	12
Shipping	12
What This Warranty Does Not Cover	12
Limitations Under This Warranty	13
Warranty Transfer	13
Service Information	14
Warranty Service Within North America	14
International Warranty Service	14
Changes To Our Products	14
Your Product	15



Safety Information

PS AUDIO®

aspen® FR30

Important Safety
Instructions



READ AND FOLLOW ALL INSTRUCTIONS
HEED ALL WARNINGS



MAGNETIC FIELD

As with most loudspeakers, the FR-30 uses strong magnets in the drivers. People with implanted medical devices should use caution around the speaker. Magnetic fields of 5G can be present up to 18" (50 cm) from certain parts of the speaker.

CAUTION HEAVY OBJECT

Lifting can cause muscle strain or back injury.

DO NOT EXPOSE THIS APPARATUS TO RAIN OR MOISTURE. OBJECTS FILLED WITH LIQUIDS, SUCH AS VASES, SHOULD NOT BE PLACED ON THE APPARATUS.

Clean only with a dry cloth. Do not place flammable material on top of or beneath the unit.

Turn off all systems' power before connecting the PS Audio® component to any other component. Make sure all cable terminations are of the highest quality.

THERE ARE NO USER-SERVICEABLE PARTS INSIDE THIS PS AUDIO PRODUCT.
REFER ALL SERVICE NEEDS TO QUALIFIED SERVICE PERSONNEL.

Please contact your authorized dealer, distributor, or PS Audio® directly if you have any questions or concerns that are not addressed in this reference manual. PS Audio®, the sine wave logo, and PerfectWave® are registered trademarks of PS Audio, Inc., and are restricted for use by PS Audio, Inc., its subsidiaries, and authorized agents. Stellar™, Power Plant™, MultiWave™, CleanWave™, and Gain Cell™ are trademarks of PS Audio, Inc.

This product was designed in Boulder, Colorado.

© 2022 PS Audio, Inc. All rights reserved. Rev B



PS AUDIO®

Introduction

aspen® FR30

Thank You

Thank you for your purchase of the PS Audio aspen FR30 loudspeaker. This is your comprehensive Operator's Guide, intended to provide a full overview of the aspen FR30's functions and capabilities. It is our intention to provide you with full details about the aspen FR30 and to answer any and all questions you may have. If you have additional questions or concerns that are not addressed in this guide, please contact us and we will be happy to assist you.

Contact Information

PS Audio, Inc.
4865 Sterling Drive
Boulder, CO 80301
1 (800) PSAUDIO
service@psaudio.com
www.psaudio.com

A Message From The Design Engineer

After nearly 50 years in business and many years in development, I am proud to present the aspen series FR30 loudspeaker. A large, but clean, modern, and elegantly slim 3-way tower speaker that is our modern take on our favorite planar magnetic hybrid loudspeakers of the past. The clarity and detail of the most modern reference loudspeaker design with an ease and musicality and power that you'd expect from PS Audio.

It incorporates much of what we have collectively learned as a company about design and manufacturing in pursuit of our ultimate sonic vision to offer a complete end-to-end system. On a personal level, it has been a dream project to put all I've learned throughout my career into a reference product for your musical enjoyment.

Chris Brunhaver
Senior Speaker Design Engineer



PS AUDIO®

Getting Started

aspen® FR30

Included with the
aspen FR30

Upper box:

Upper speaker enclosure in cloth bag

Cloth magnetic grille

Accessory box – this product manual, jumpers (for connecting the upper and lower cabinets and configuring the inputs for mono or bi-wiring), tool kit (allen wrenches for all of the metric socket head screws used throughout).

Lower box:

Lower speaker enclosure in cloth bag

Cloth magnetic grille

Threaded carpet sliders for ease of positioning the speaker during setup

Unpacking
Instructions

The packaging cartons are held together by four plastic packaging clips around the base of the box.

To open the clips, squeeze the to vertical ribs and pull outwards and upwards. Completely remove the clips from the box.

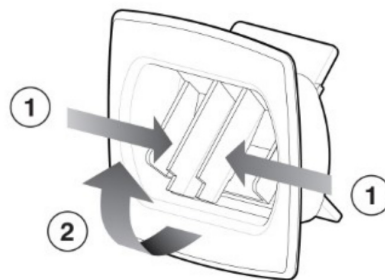



PS AUDIO®

Getting Started

aspen® FR30

Unpacking
Instructions,
Continued

From there, lift the top of each carton upwards and remove.

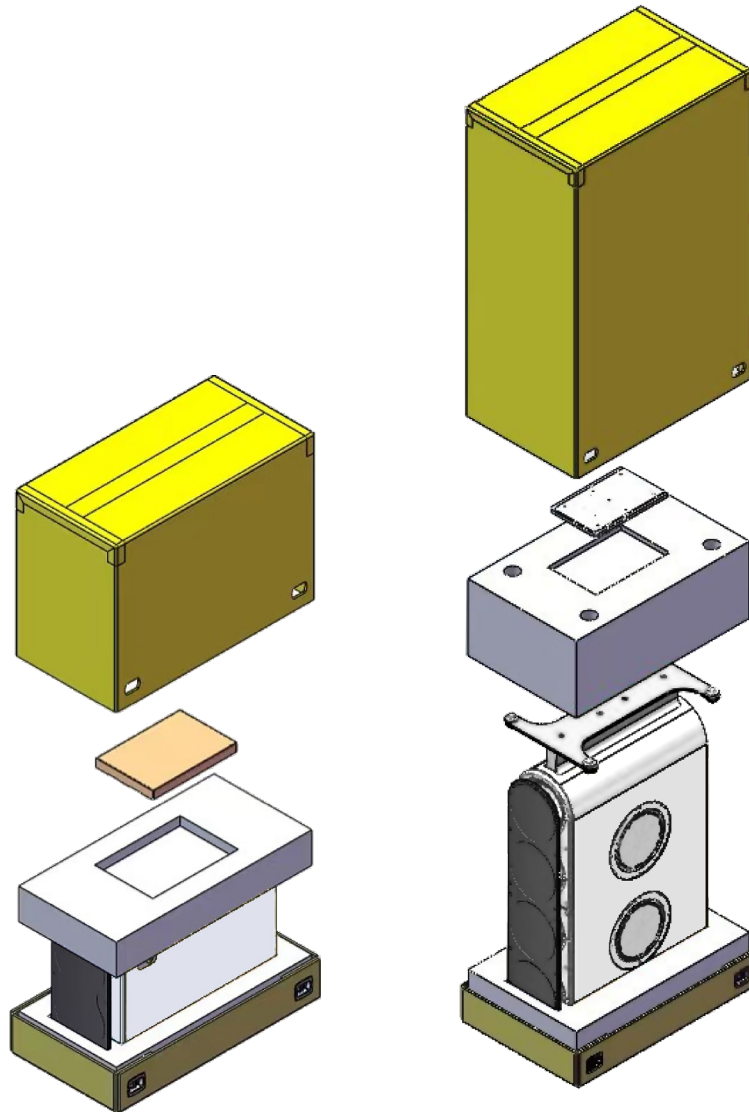

Note: The cloth bags covering each speaker box are not shown.



PS AUDIO®

Getting Started

aspen® FR30

Configuring Speaker Feet

For hard floors – twist to remove bottom 0.375” spiked tip from feet to expose the black plastic disc underneath.

Note: For carpeted floors – spiked tips should be removed only after standing bottom speaker cabinet up.

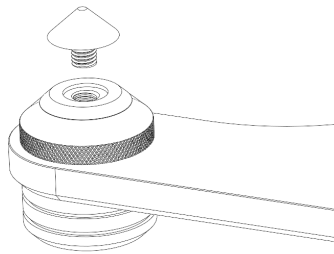

The foam covering the metal base of the bottom speaker enclosure can be placed immediately to the side and used as a fulcrum to tilt and rotate the speaker onto its spiked feet.

The bottom .375” spiked tips can then be removed and the included black carpet sliders (located in the foam packaging covering the metal base of the speaker) can be screwed into place.

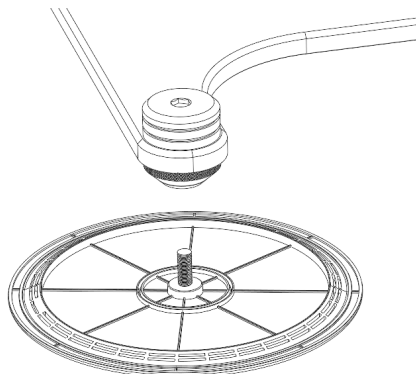

This way, the speaker can be easily slid around during initial listening and setup. When the final speaker location is determined, replace carpet sliders with the spiked tips for best performance.



PS AUDIO®

Getting Started

aspen® FR30

Configuring
Speaker Feet,
Continued

These are leveling feet as well. Loosen the top gap of the foot and adjust the bottom spiked foot until the speaker is level, and then tighten the top cap into place to lock them in position.

Aftermarket isolation feet can also be used with a compatible M8 X 1.25 thread to screw into the aluminum base plate.

Speaker
Accessories

Please open the accessory box located inside the upper speaker packaging. This box includes this manual, jumpers (for connecting the upper and lower speaker enclosures and configuring single/bi-wiring operation) and a set of high-quality allen wrenches for tightening or replacing speaker components.

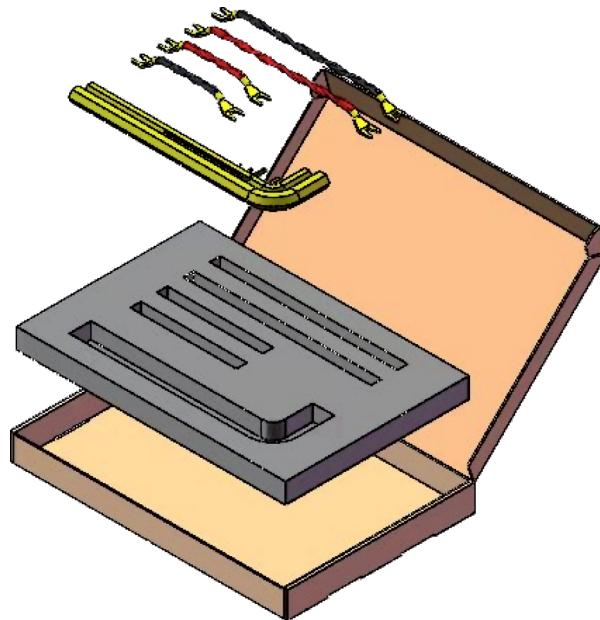



PS AUDIO®

Getting Started

aspen® FR30

Assembling Upper and Lower Speaker Enclosures

The aspen FR30 features a two piece enclosure for optimal acoustic and mechanical performance and ease of installation. The cabinets are combined with a sliding mechanism and held in place with spring loaded bearings.

To assemble, simply place the upper enclosure midway back on the lower enclosure, then slide it forward until you hear a small “click”.

Electrical connections are covered in the next section.

To disassemble, reverse the process.

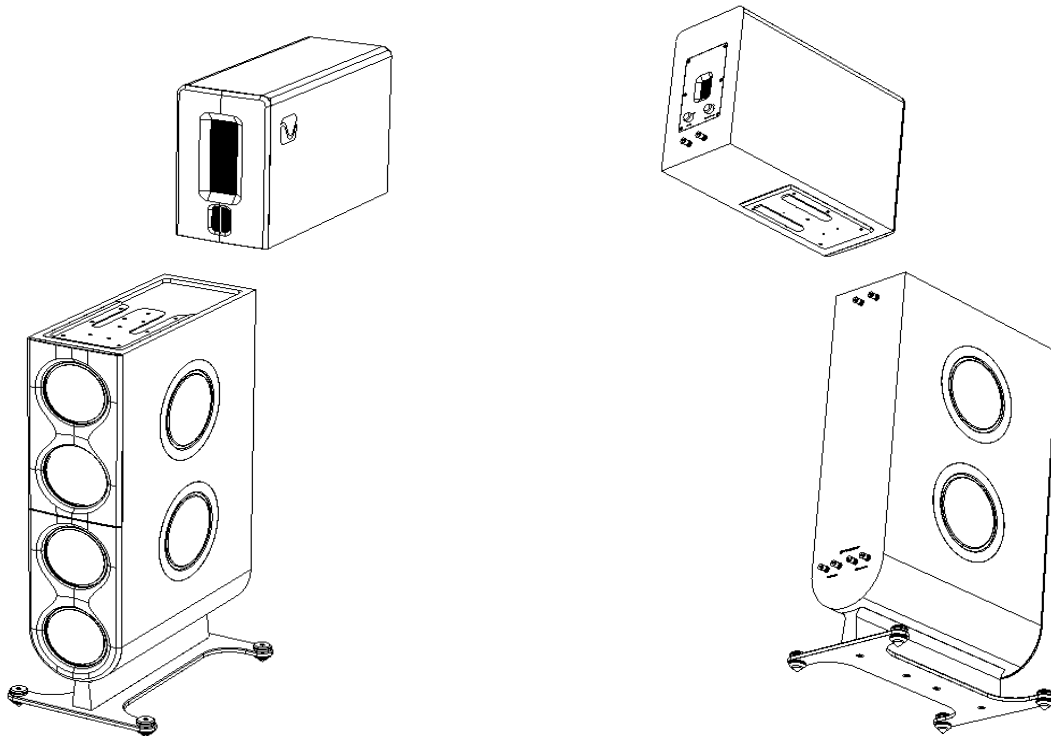



PS AUDIO®

Getting Started

aspen® FR30

Jumper / Input
Wiring
(bi-amp, bi-wiring)

The FR30 comes with four input terminals as shown. For single wiring/amping, connect the set of longer jumpers from the accessory box to parallel wire the black and red terminals sets together (black to black and red to red) as shown below. Connect a single amplifier to the left set of terminals.

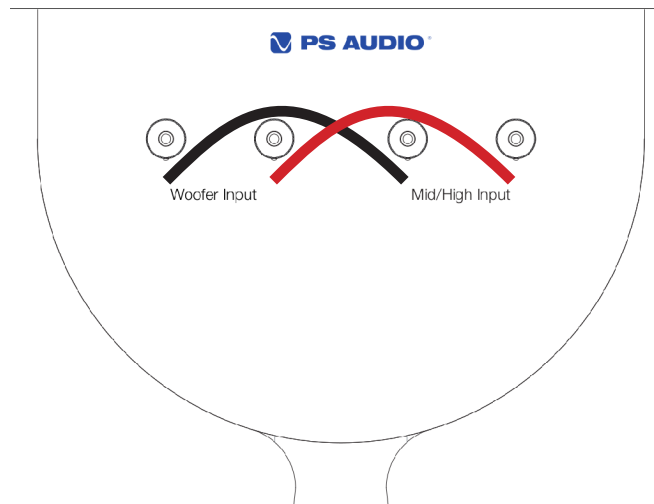

For bi-wiring/bi-amping do not connect the jumpers (as seen below).

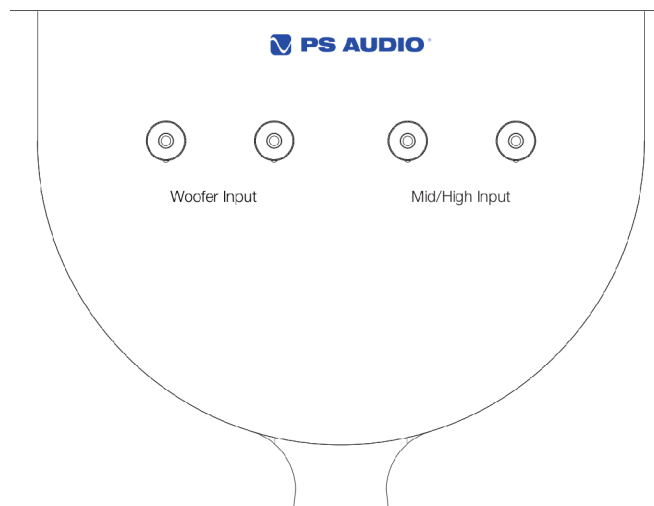

The short set of jumpers is used to connect the upper enclosure to the bottom enclosure (black to black, red to red).

Note: If using banana plugs, remove red and black plugs from binding posts.



Basic Setup and Placement

Loudspeakers and rooms work together as a system and, to get the best performance, great care in setup is important to optimize the listening experience.

Some helpful tools include a tape measure (or laser measurement tool), pen/paper to note the distances and listening impressions, and some demo music.

Distances to sidewalls/front wall:

One of the most important aspects of speaker placement is distance from boundaries. In particular, best performance is typically found when the speaker is a minimum of 3 ft from the side wall and placed symmetrically (or very close to that) from sidewall boundaries. This distance minimizes early reflections off the wall from interfering with the tonality of the sound coming directly from the speaker.

Distance from the front wall (if in a dedicated space where the speaker can be placed out into the room somewhat) should be chosen through listening but, in general, should start around 18 inches from the front wall. From there, listen to acoustic/vocal music with good bass and percussion and gradually inch the speakers away from the wall, assessing the sound as you go. (You want to make sure that the lower range voice and bass instruments are the most natural sounding and balanced with the midrange.) Keep inching both speakers into the room until the current position sounds worse than the previous position. Then move them back to the previous position where the tonal balance was the most natural.

Speaker width and toe-in:

In general, your listening position should be about 20% outside of an equilateral triangle formed by the width of the speakers (+/- 30 degrees from center). For instance, if the listening position is 10 ft (~3 m) from the speakers, a starting width for the speakers should be ~8 ft (~2.4 m).

Placing the speakers closer together gives a bit less “width” to the sonic image but can give a stronger phantom center image and more warmth and bloom in the low midrange.

The speakers should be toed-in a little, aimed at a point in space about 3 ft behind the listening position.

Further pointing of the speakers towards the listening position will increase “focus” and the level of the extreme treble at the expense of the spaciousness and “width” (perception of sound coming from outside the width of the speakers).



PS AUDIO®

Operation Guide

aspen® FR30

Rear Panel Controls

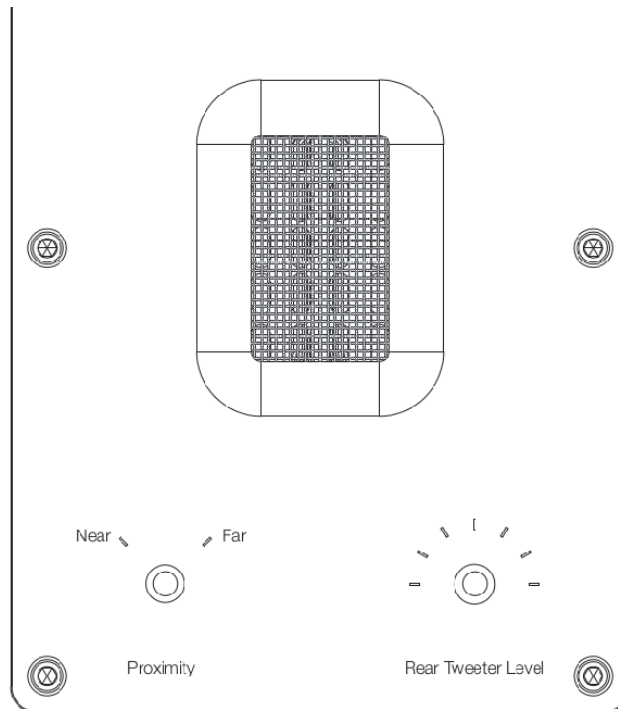

When looking at the rear of the speaker, there are two knobs. The knob on the left should be set to “far” unless the speaker is <2ft from two nearby boundaries and the sound is too “chesty”, “thick” or “full” in the low midrange. Then the left knob can be set to the “near” position, which raises the level of the midrange and tweeter to compensate for this boundary reinforcement from the nearby walls.

The knob on the right is rear tweeter level. Adjust this “to taste”. The extreme treble of most rooms can lack some “air” and spaciousness, particularly in large rooms or those with a lot of furnishings that are acoustically absorptive in nature (drapes/curtains, thick carpets etc.). There is no “right” or “wrong” setting, just the one that you prefer with this control. You have five settings from “off” to different levels of “on,” which adds additional treble output from the rear of the speaker to slightly change the tonal balance in-room, without affecting the direct sound of the speaker.



PS AUDIO®

Specifications

aspen® FR30

aspen FR30
Specifications

Color Options	Pearl White, Sable Black
Enclosure Type	Two piece – Sealed upper cabinet mid-tweeter module, Passive radiator lower cabinet (4 10” side-firing passive radiators)
High Frequency Transducer	2 x 2.5” planar magnetic with Teonex diaphragm
Mid Frequency Transducer	10” planar magnetic with Teonex diaphragm
Low Frequency Transducer	4 x 8” woofers, cast frame, aluminum cone, 12lb advanced magnet structure
Crossover Frequency	400 Hz, 2500 Hz – Linkwitz-Riley 4th order acoustic
Sensitivity (2.83V @ 1M)	88 dB
Nominal Impedance	4 ohm (3.2 ohm minimum impedance).
Recommended Amplifier Power	100-600W
Frequency Response	23Hz-20kHz (-6dB) half space 20 Hz (-6dB) in-room
Dimensions (HxWxD)	60.5” x 16” x 25.75” with base (10” width not including base)
Net Weight	230 lbs (104.5 kg)



Warranty Information

PS AUDIO®

aspen® FR30

Registering Your Product

By registering your product, you are validating the start date of your limited warranty. This limited warranty is in effect for 3 years from the date the unit was first purchased from PS Audio or its dealers and agents. If you do not register your product within 30 days of service, a copy of your purchase receipt from an authorized PS Audio dealer may be used as proof of purchase to establish the warranty start date. If no proof of purchase from an authorized PS audio dealer or registration is provided, the production date of the product will be used to determine the warranty start date. You can register your product online, by phone, by mail, or by email.

What This Warranty Covers

This warranty covers defects in material and workmanship for products purchased from PS Audio or its authorized dealers and agents. In the event your product fails, your sole remedy under this limited warranty shall be to return the product to PS Audio or an authorized PS Audio repair center. At the option of PS Audio, the product will be repaired without charge for parts or labor, replaced, or the purchase price refunded through the original point of purchase.

Shipping

You are responsible to pay for the safe and proper shipment of the warranted product to PS Audio or its authorized repair center. Under this limited warranty, PS Audio or its authorized repair center will pay the cost of returning the repaired or replacement product to you.

What This Warranty Does Not Cover

This warranty does not cover damage due to:

- Accidents, carelessness, improper transportation, misuse, neglect, or abuse
- Failure to follow the operating instructions that are provided by PS Audio in the Owner's Reference Manual (available for download at www.psaudio.com)
- Use in any manner inconsistent with PS Audio's operating instructions (available for download at www.psaudio.com)
- Lack of routine maintenance
- Connection to an improper voltage supply
- Alterations or modifications to the unit
- Improper or unauthorized repair, including repairs not authorized by PS Audio or a PS Audio authorized repair center
- Fire, lightning, flood, "Acts of God," or other contingencies beyond the control of PS Audio
- Products purchased through an unauthorized source (if you have questions as to whether or not a dealer is authorized, please contact customer support at www.psaudio.com)
- Products with a factory-applied serial number that has in any way been altered, defaced, or removed



Warranty Information

PS AUDIO®

aspen® FR30

Limitations Under This Warranty

In no event will PS Audio's liability to you exceed the original purchase price of your unit. This warranty does not cover the cost of custom installation, customer instruction, setup adjustments, or signal reception problems. Consequential and incidental damages are not covered under this warranty. However, some states do not allow the exclusion or limitation of incidental or consequential damages, so this limitation or exclusion may not apply to you. In the event that your warranted product cannot be repaired, PS Audio will either replace or refund the cost of the unit. We reserve the right to replace any out-of-stock, discontinued, or limited edition products with a comparable product. Discontinued products may not be available for warranty replacement.

Warranty Transfer

This warranty is for the benefit of the original purchaser of the product. The warranty may be transferred to a subsequent purchaser during the 3 year warranty period. To do this, you must contact PS Audio directly to set up a transfer of warranty registration.



Service Information

PS AUDIO®

aspen® FR30

Warranty Service
Within North
America

Please contact PS Audio customer support for service assistance, help with locating an authorized PS Audio repair center, help with the operation of a product, or for more information.

Obtaining An RMA#

In order to receive warranty service, you must first obtain a Return Merchandise Authorization Number (RMA#) prior to returning any item. Please contact PS Audio or an authorized PS Audio repair center to receive an RMA#. The RMA# must be on all returned items. If it is not clearly marked, PS Audio will return the package back to you, freight collect.

Packaging and Shipping

Original packaging should be used for the safe transit of your PS Audio unit to the repair center. If you do not have the original packaging, PS Audio can sell and ship replacement packaging to you. You are responsible for the cost of shipping the product to a PS Audio authorized repair center. You should insure the product for its full retail cost, in the event it gets lost or damaged in transit. PS Audio is not responsible for damage incurred during the transit of products sent to us. Shipping your product in non-PS Audio packaging may void this warranty. PS Audio reserves the right to charge you for new factory packaging to return your product after a repair.

State Law

This warranty gives you specific legal rights. You may also have other rights, which vary from state to state.

International
Warranty Service

PS Audio has authorized distribution in many countries of the world. In each country, the authorized importing distributor has accepted the responsibility for warranty of the products sold by that distributor. Warranty service should be obtained where the product was purchased.

Changes To Our
Products

PS Audio reserves the right to modify the design of any product without obligation to purchasers of previously manufactured products, and to change the prices or specifications of any products without notice or obligation to any person.



PS AUDIO®

Your Product

aspen® FR30

Your Serial
Number

Your Purchase
Information

Date of Purchase



PS AUDIO[®]

Notes

aspen[®] FR30



PS AUDIO®

Notes

aspen® FR30



Thanks for being a part of the PS Audio Family

At PS Audio, we're family.

Not just a family that runs in bloodlines, but in frequencies.

Because while we may not all share the same genes here, we are all related by a passion, nay, obsession with listening to the music we love at the highest, most breathtaking quality possible.

And in our minds, that makes us kin.

In fact, we believe that every nutty, hertz counting audiophile out there is part of our tribe.

That's how we've built our company over the last 50 years - with the kind of care and respect that you give to your family.